



PANORÁMICOS
PANORAMIC LIFTS

ASCEL[®]
ascensores de Galicia

INSTALACIONES
INSTALLATIONS



Ascensor circular.
Circular lift.

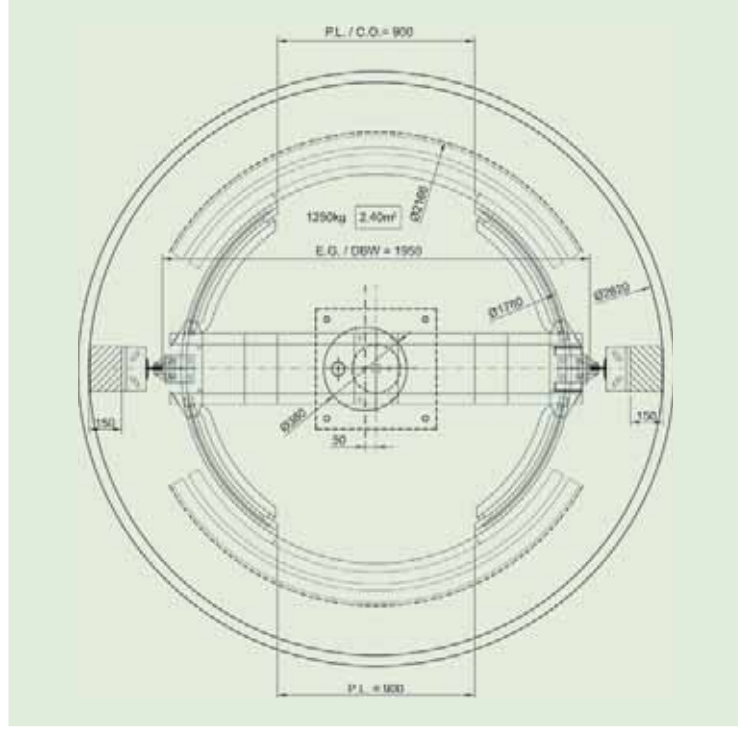

Ciudad de las Ciencias. Valencia. Ascensor hidráulico circular. Pistón enterrado. 800 kg. Altura: 2 paradas.
City of Arts and Sciences, Valencia_Hydraulic circular lift. Buried jack. 800 kg. Height: 2 stops.





Complejo de apartamentos Torre DosCalas. Benidorm_8 Ascensores 630 Kg. Altura: 33 paradas.
 Apartments Resort Torre Dos Calas. Benidorm_8 lifts 630 Kg. Height: 33 stops.

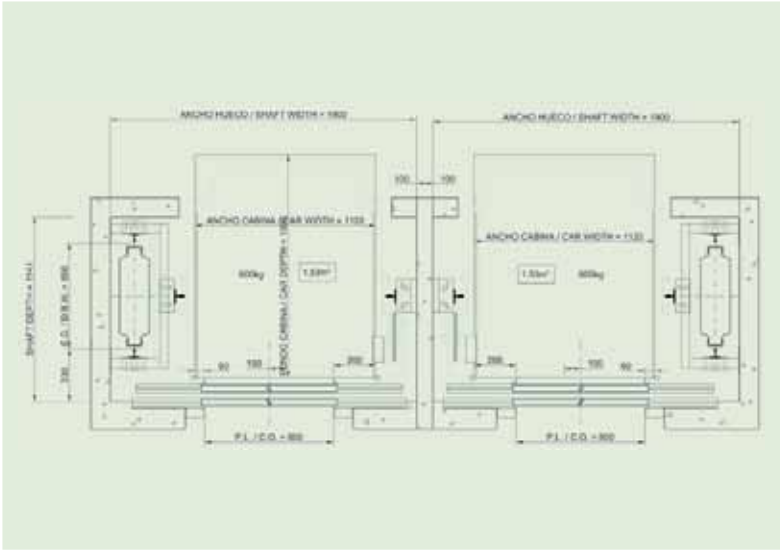

Hotel Rio Park. Benidorm_ Ascensores Dúplex.
 Hotel Rio Park Benidorm. Duplex lifts.



Hotel Rio Park. Benidorm_6 ascensores eléctricos dúplex 600 kg. Altura: 14 paradas.
Hotel Rio Park Benidorm_6 Electric Duplex lifts. 600 Kg. Height: 14 stops.

Estación de tren de alta velocidad de Padova (Milano).
High-speed railway station of Padova (Milano).





Ascensor circular.
Circular lift.

Edificio de oficinas de Constructora. Palma de Mallorca_ Ascensor hidráulico circular 600 kg. Pistón enterrado. Altura: 4 paradas.
Constructora office building. Palma de Mallorca_600 kg. circular hydraulic lift. Buried jack. Height: 4 stops.

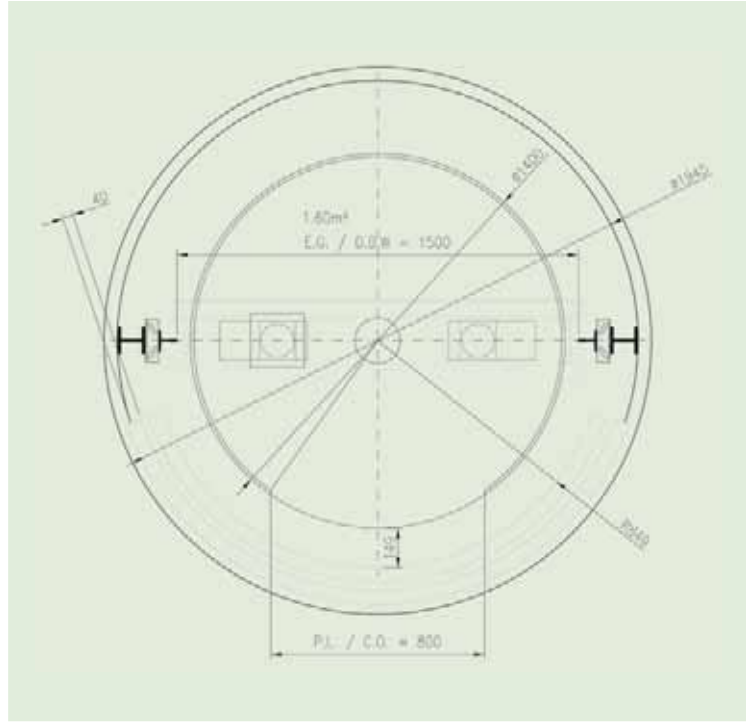

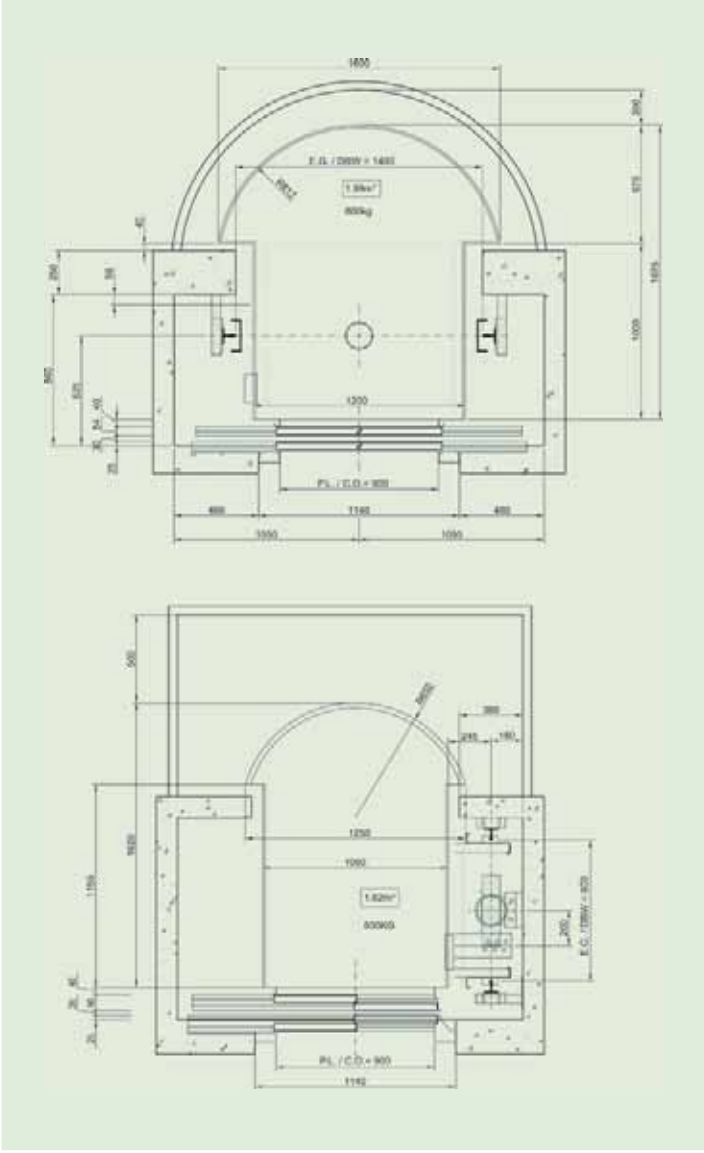

Ascensor con cabina semicircular adaptada a hueco.
Lift with semicircular car adapted to shaft.



Panorámico en hotel. Italia.
Panoramic lift in hotel, Italy.



Edificio de oficinas. Puerto de Valencia_ Ascensor hidráulico 600 kg. Altura: 8 paradas.
Office building. Port of Valencia. 600 kg. Hydraulic lift. Height: 8 stops.

CABINAS CARS

Ascensor circular.
Circular lift.



Vivienda particular_ Ascensor con cabina semicircular recta a hueco.
Private house _ Lift with semicircular car straight to shaft.



Otras opciones de cúpulas.
Other dome options.

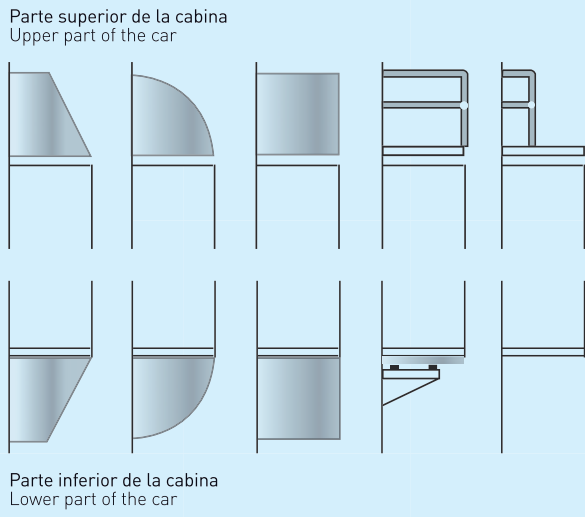

La forma final de la cúpula irá en función de la silueta de cabina.

The final shape of the dome will depend on the car silhouette.





Bajotecho cabina de fibra óptica.
Optical fiber car ceiling.

Bajotecho cabina halógenos led.
Car ceiling with halogen leds.

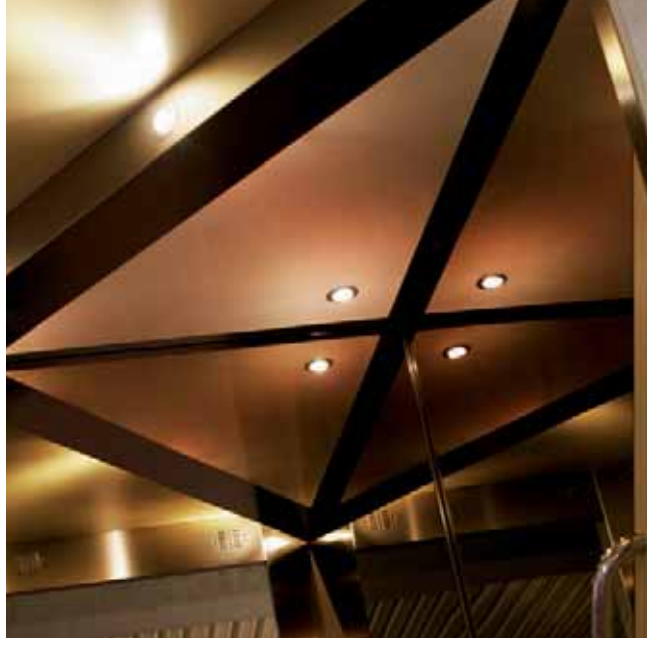

Bajotecho cabina de fibra óptica_ Hotel Poseidón. Benidorm.
Optical fiber car ceiling_ Hotel Poseidon, Benidorm.



BAJOTECHOS CEILING

Diferentes propuestas donde la luz y el racionalismo son los protagonistas. Posibilidad de cualquier otro diseño.

Different proposals in which the light and rationalism play the leading role. Possibility of any other design.

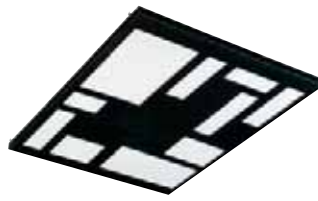

Chapa Perforada (Skinplate o Inox.)
Perforated steel sheet
(Skinplate or stainless steel)



Skinplate halógenos
Skinplate with halogens

ACABADOS FINISHINGS

Los diferentes acabados permiten personalizar el producto al máximo y adaptarlo a las necesidades estéticas tanto del conjunto como del edificio.

The different finishings allow to personalize the product to a very high degree and to adapt it to the aesthetic needs of the surroundings and the building.

ACERO INOXIDABLE
STAINLESS STEEL

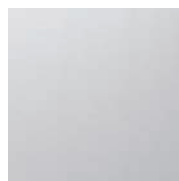

Satinado / Satin

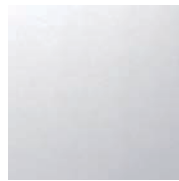

Brillo / Shiny

ACERO INOX. COLOR
COLOURED
STAINLESS STEEL



Verde / Green

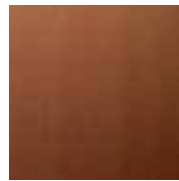

Rojo / Red



Azul / Blue

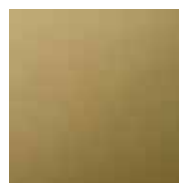

Oro / Golden

ACERO INOX.
TEXTURIZADO
TEXTURED
STAINLESS STEEL



Canvas / Canvas



Cuero / Leather

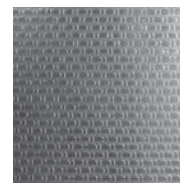

Lino / Linen

OPCIONALES*
OPTIONALS*

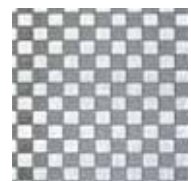

Checks / Checks

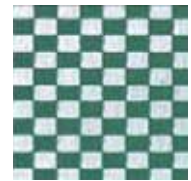

ColourTex Checks Green



Pearl / Pearl

* CONSULTAR
DISPONIBILIDAD.

* CONSULT
AVAILABILITY.

SUELOS FLOORS

Suelos de cabina personalizables, con diferentes acabados que se adaptan a cada necesidad estética.

Car floors to meet the taste of the customer, with different finishes that adapt to every aesthetic requirement.

PERGO-MADERA
PERGO WOOD

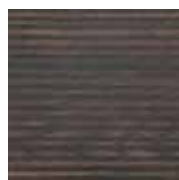

Corteza Álamo Oscuro
Dark Poplar Bark



Pino Blanco
White Pine

GRANITOS
GRANITE



Azul Labrador
Farmer Blue

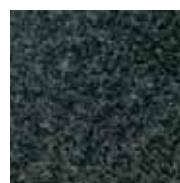

Negro Sudáfrica
South Africa Black

SILESTONE
SILESTONE



Beige Daphne
Daphne Beige



Gris Expo
Expo Grey



Inox. halógenos
Stainless steel halogens

Espejo halógenos
Mirror halogens

Cristal matizado
Matt glass

Rejilla blanca
White grid

BOTONERAS CABINA CAR OPERATING PANEL

Los ascensores especiales se merecen elementos exclusivos. Una forma única de marcar la tendencia combinando funcionalidad y diseño.

Special lifts deserve selected elements. A unique shape to label tendency combining functionality and design.



Botonera cabina en cristal.
Glass car operating panel.

Botonera cabina serie Epsilon.
Car operating panel series Epsilon.



Botonera cabina serie B50.
Car operating panel series B50.

Pulsadores.
Buttons.



Epsilon



B 50 Q

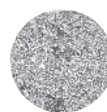

BAS 120



B 50 R

Botonera cabina tipo pasamanos.
Car operating panel type handrail.



Indicador de posición retro.
Indicator of retro position.



FORMAS SHAPES

Se representan las formas básicas. Para otras, consultar.

The basic shapes are represented. For other shapes, please consult.

Pasamanos obligatorio en zona de cristal panorámico.

Posibilidad de formas y anclajes personalizados.

Opcionales fijaciones a postes o suelo según diseño seleccionado.

Cumplimiento de la Norma UNE-EN 81-70

Obligatory handrails in glass area panoramic lift.

Possibility of custom tailored shapes and anchorages.

Optional fittings to posts or floor according to selected design.

Compliance with UNE-EN 81-70 Standard.

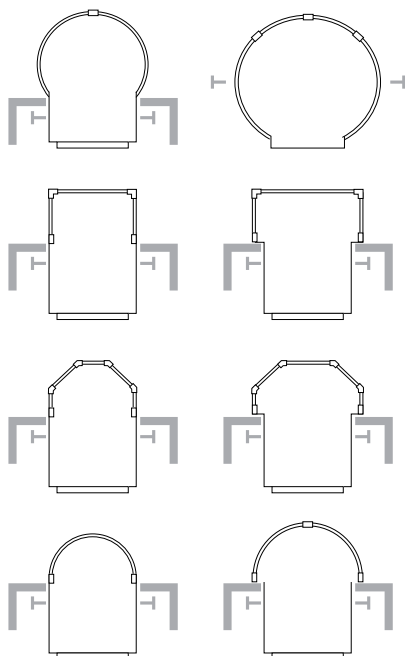

PASAMANOS CON FIJACIONES A LOS POSTES
HANDRAIL WITH FITTINGS TO THE POSTS

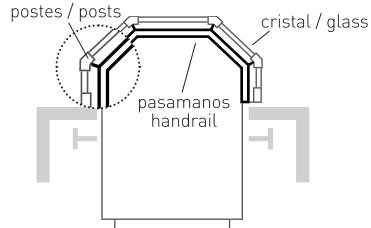

PASAMANOS CON PIES AL SUELO
HANDRAIL WITH BARS TO THE GROUND

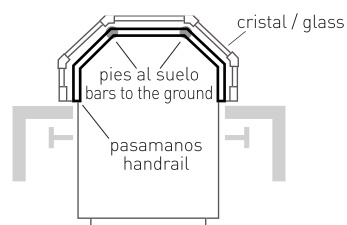

CÚPULAS DOMES

Ver otras opciones de cúpulas en página 21.
See other options of domes on page 21.

Palacio Joan de Valeriola_ Fundación Chirivella Soriano. Valencia.
Centro privado de arte contemporáneo. Ascensor hidráulico con pistón enterrado. 1.000 Kg. Puerta completa de vidrio.
Palace Joan de Valeriola _ Fundación Chirivella Soriano. Valencia.
Private Centre of Contemporaneous Art. Hydraulic lift with buried jack. 1.000 kgs. Complete glass door.



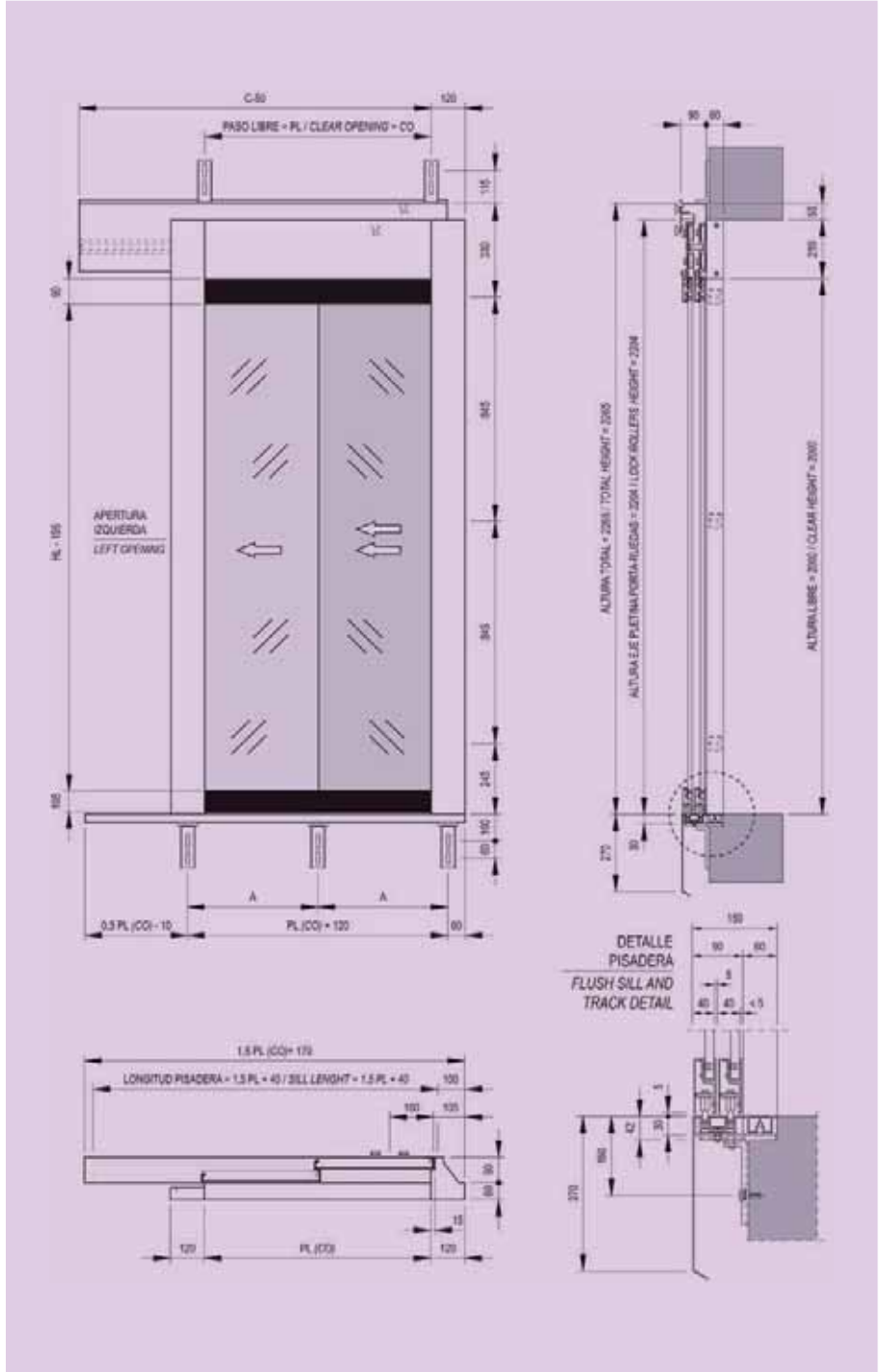

Puerta cristal total.
Complete glass door.

Puertas gran mirilla circular.
Circular doors big vision panel.



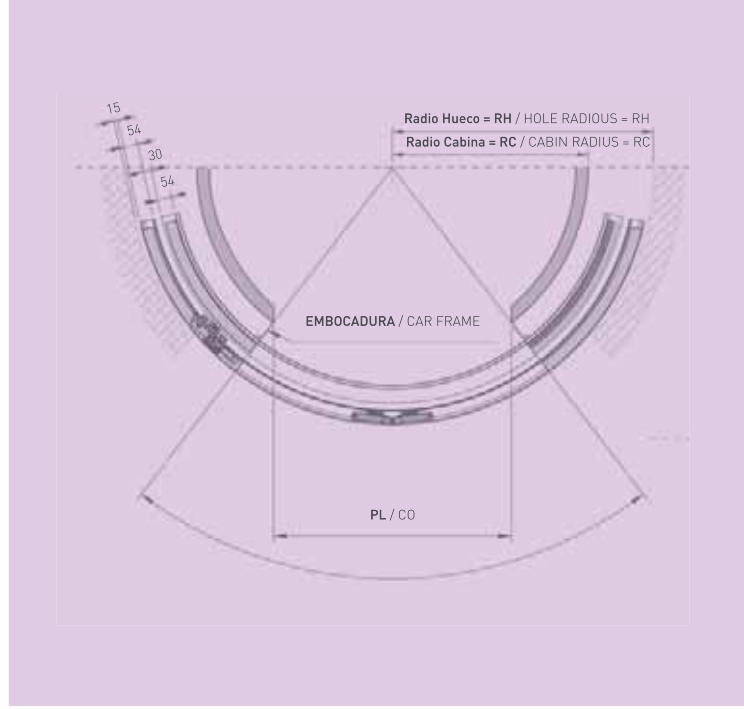

Puerta circular sin marco.
Circular door without frame.

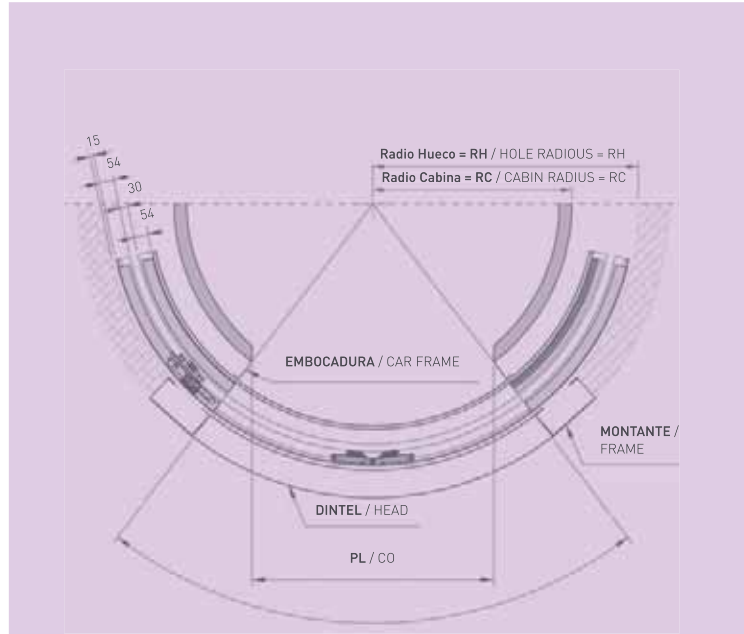

Puerta circular con marco.
Circular door with frame.

30
29
28
27

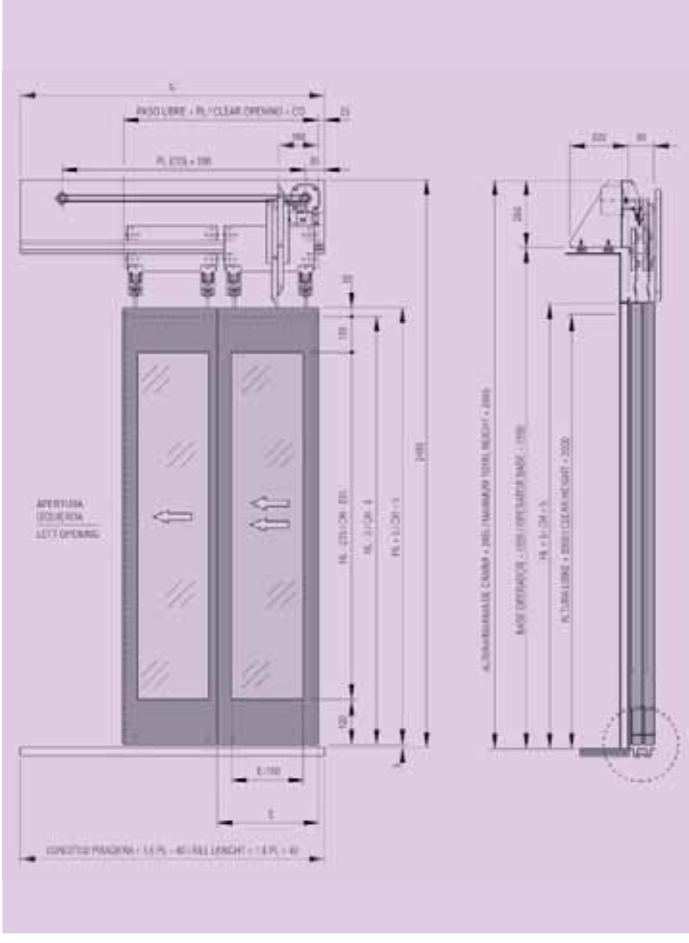

Puerta gran mirilla.
Door big vision panel.



Puerta cristal total_Museo de arte moderno de Catalunya.
Complete glass door_Museum of Catalunya.





Puerta gran mirilla.
Door big vision panel.

CHASIS FRAMES

Showroom Raloe / Raloe Showroom



CHASIS DE MOCHILA
RUCKSACK FRAME



CHASIS DE PÓRTICO
ARCADE FRAME

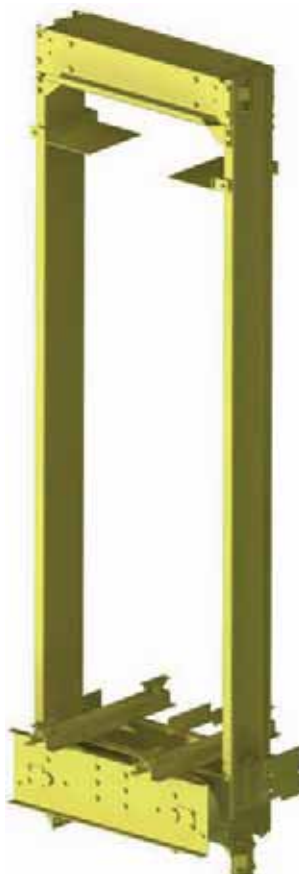

Los chasis, tanto los de pórtico como los de mochila, además de disponer de la resistencia adecuada y garantizar un excelente deslizamiento y seguridad, pueden personalizarse. En los ascensores panorámicos, debido a su visibilidad, la estética es fundamental, por eso se puede elegir el acabado cromático que más se ajuste al entorno de su ubicación.

Both the arcade and the rucksack frame possess the adequate resistance and guarantee an excellent gliding and security and they can also be customs tailored. In the panoramic lifts, due to their visibility, the aesthetics are fundamental. Therefore you can choose the chromatic finish that adapts most to its location.

PINTURAS AL POLVO
POWDER PAINT

Colores y texturas especiales / Special colours and textures

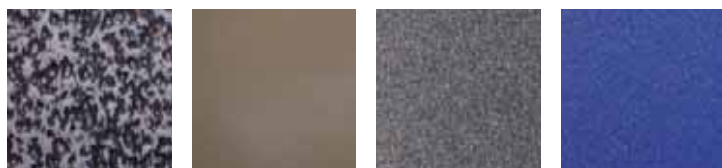

Colores RAL / RAL colours

